

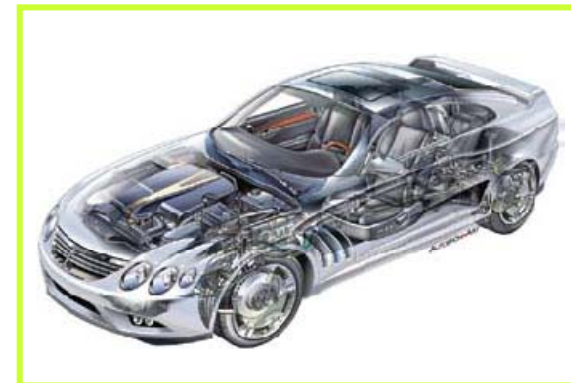

- NXP
- >4000 R&D staff
- Global presence
- Eindhoven, Nijmegen
- Semiconductor chips and components
 - High Performance Mixed Signal
 - Automotive
 - Identification
 - Standard Products
- Sales 5.4B\$ (2008)
- R&D 1.1B\$ (2008)



- First to launch a One-Chip-key including immobilization, microcontroller and radio transmitter
- #1 in Automotive In-Vehicle networking (CAN, LIN, Flexray)
- 1 in 3 vehicles produced annually uses one or our sensors
- Early leader in Telematics



Sterktes

1. Mixed-Signal IC design en technologie
 1. HV IC technologie
 2. Nauwkeurige meetfuncties
2. Systeem kennis
3. Modellering

Toelichting:

NXP Research innoveert in oplossingen

- Voor nieuwe markten *en/of*
- Gebaseerd op innovatieve concepten *en/of*
- Met gebruik van nieuwe technologie

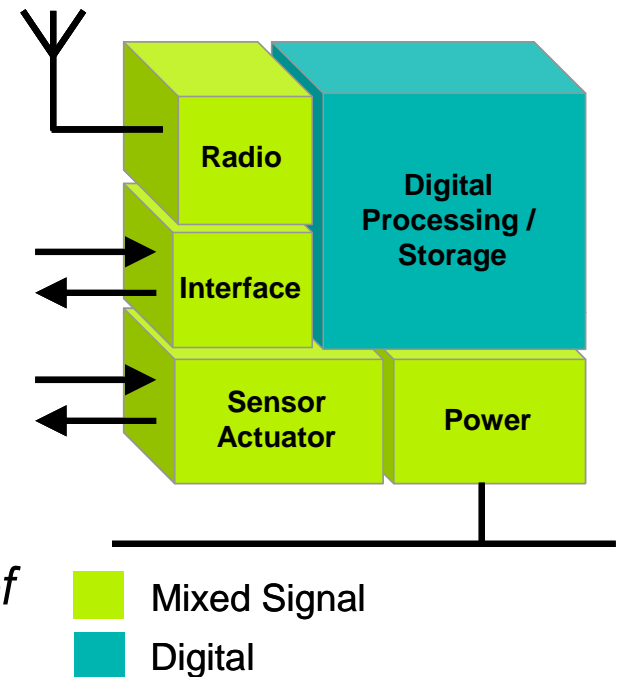

Kansen

1. Samenbrengen van kennis op gebieden
 1. Batterij
 2. Battery management
 3. Toepassing
2. Identificeer innovatieve architecturen, gekoppeld aan optimalisatie van de individuele componenten

